

- > Port size G1/2 ... G1
- > Ported regulators for general purpose and high flow pneumatic applications
- > Large diaphragm provides accurate and quick response to changing flow demands and line pressure
- > Balanced valve minimizes effect of variations in inlet pressure on outlet pressure
- > Extensive range of applications



### Technical features

#### Medium:

Compressed air only

#### Maximum inlet pressure:

28 bar (406 psi) max.

#### Pressure range:

0,1 ... 3,5 bar (1 ... 50 psi),  
0,2 ... 8 bar (3 ... 116 psi)  
0,7 ... 17 bar (10 ... 246 psi)  
(1/2" version only)

#### Port sizes:

1/2", 3/4" or 1"

#### Gauge port:

1/8 PTF with PTF main ports  
Rc1/8 with ISO G main ports

#### Ambient/Media temperature:

-20 ... +80°C (-4 ... +176 °F)

Version with gauge:

-20° ... +65°C (-4° ... +149°F)

Air supply must be dry enough to avoid ice formation at temperatures below +2°C (+35 °F)

#### Materials:

Body: Zinc alloy

Bonnet: Aluminium alloy

Bottom plug: Glass filled nylon for G 1/2, aluminium for G 3/4 and G 1

Adjusting screw: Steel-plated

Elastomers: Synthetic rubber

### Technical data, standard models

Symbol	Port size	Pressure range (bar)	Flow * (dm <sup>3</sup> /s)	Relieving	Adjustment	Weight (kg)	Model
	G1/2	0,1 ... 3,5	60	Standard	T-bar	1,40	20AG-X4G-PD100
	G1/2	0,2 ... 8	60	Standard	T-bar	1,30	20AG-X4G-PH100
	G1/2	0,7 ... 17	60	Standard	T-bar	1,30	20AG-X4G-PJ100
	G3/4	0,1 ... 3,5	80	Standard	T-bar	2,75	20AG-X6G-PD100
	G3/4	0,2 ... 8	80	Standard	T-bar	2,85	20AG-X6G-PH100
	G1	0,1 ... 3,5	100	Standard	T-bar	2,44	20AG-X8G-PD100
	G1	0,2 ... 8	100	Standard	T-bar	2,90	20AG-X8G-PH100

Typical flow with 7 bar inlet pressure, 4 bar set pressure and 1 bar drop from set.

### Option selector

Diaphragm	Substitute
Relieving (standard)	X
Non-relieving - (no digit)	
Port size	Substitute
1/2"	4
3/4"	6
1"	8

20AG-★ ★ G-★ ★ 1 ★ ★

Options *2)	Substitute
T-bar handle (standard)	00
Panel mounted with plastic handwheel, 1/2" only	03
Pressure ranges *1)	Substitute
0,1 ... 3,5 bar	D
0,2 ... 8 bar	H
0,7 ... 17 bar, 1/2" only	J
Thread form	Substitute
PTF	A
ISO G parallel	P

\*1) Outlet pressure can be adjusted to pressures in excess of, and less than, those specified. Do not use these units to control pressures outside of the specified ranges.

\*2) Other seals or use other gases might be possible - please contact Norgren

**Flow characteristics**

Inlet pressure: 10 bar, port size: 1/2"  
Range: 0,2 ... 8 bar

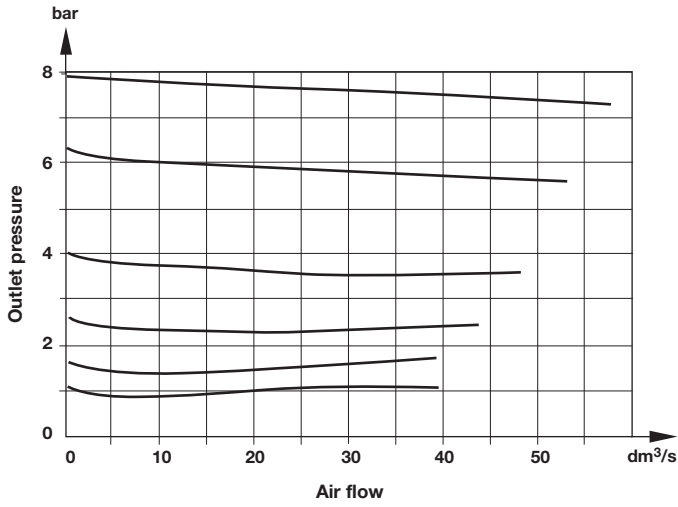

Inlet pressure: 10 bar, port size: 1"  
Range: 0,2 ... 7 bar

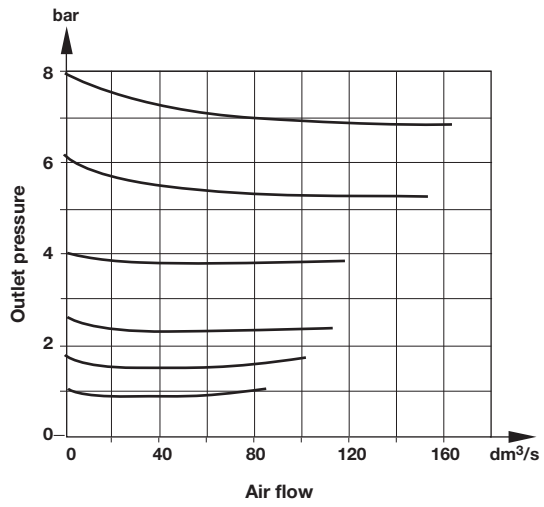

**Accessories**



**Accessories**

Wall mounting bracket



1

Port size

G 1/2	18-001-005
G 3/4 & G 1	18-001-029

**Service kits**



Model

20AG-X4G/**100 (relieving)	20AG-X4-100
20AG-4G/**100 (non-relieving)	20AG-4-100
20AG-X6G/**100 (relieving)	20AG-X8-100
20AG-6G/**100 (non-relieving)	20AG-8-100
20AG-X8G/**100 (relieving)	20AG-X8-100
20AG-8G/**100 (non-relieving)	20AG-8-100

**Gauges**

Center back connection, white face (full technical specification see datasheet 8.900.900)



2

Pressure range bar *1	MPa	psi	Ø	Thread size	Model
0 ... 4	0 ... 0,4	0 ... 58	50 mm	R1/8	18-013-011
0 ... 10	0 ... 1	0 ... 145	50 mm	R1/8	18-013-013
0 ... 25	0 ... 2,5	0 ... 362	50 mm	R1/8	18-013-014

\*1) primary scale

Center back connection, black face for North America (full technical specification see datasheet 8.900.900)



2

Pressure range psig *1	bar	MPa	Ø	Thread size	Model
0 ... 60	0 ... 4	0 ... 0,4	2" (50 mm)	1/8 NPT	18-013-202
0 ... 160	0 ... 11	0 ... 1,1	2" (50 mm)	1/8 NPT	18-013-204
0 ... 400	0 ... 28	0 ... 2,8	2" (50 mm)	1/8 NPT	18-013-206

\*1) primary scale

**Dimensions**  
**Standard version**

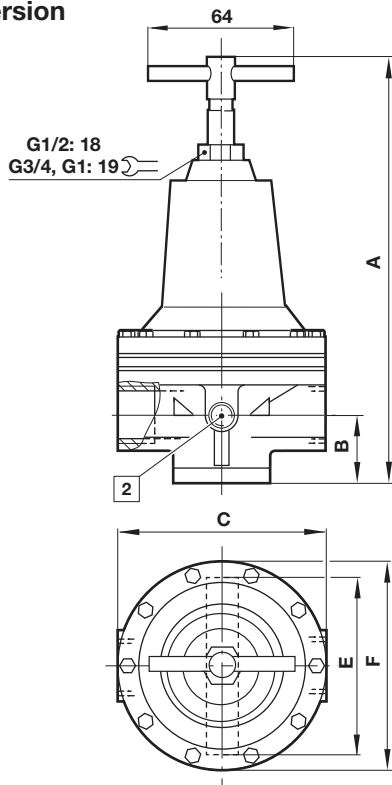

2 Gauge port

Port size	A	B	C	E	Ø F	P
G1/2	162	36	86	82	83	179
G3/4	232	41	124	108	124	245
G1	232	41	124	108	124	245

**Bracket mounting**

Dimensions in mm  
Projection/First angle

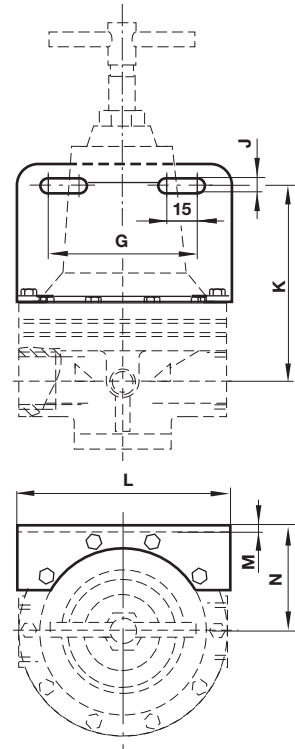

Port size	G	J	K	L	M	N
G1/2	63	7	73	83	2	57
G3/4	98	8	80	124	2	75
G1	98	8	80	124	2	75

**Panel mounted with plastic handwheel, 1/2" only**

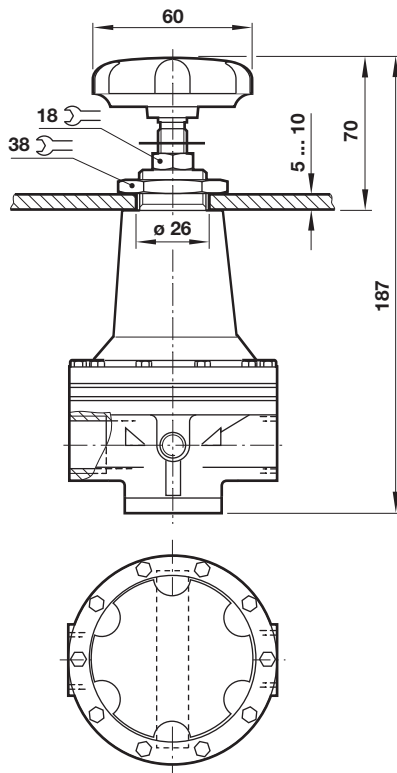

## Warning

These products are intended for use in industrial compressed air systems only. Do not use these products where pressures and temperatures can exceed those listed under

»**Technical features/data**«.

Before using these products with fluids other than those specified, for non-industrial applications, life-support systems or other applications not within published specifications, consult IMI NORGREN.

Through misuse, age, or malfunction, components used in fluid power systems can fail in various modes.

The system designer is warned to consider the failure modes of all component parts used in fluid power systems and to provide adequate safeguards to prevent personal injury or damage to equipment in the event of such failure.

System designers must provide a warning to end users in the system instructional manual if protection against a failure mode cannot be adequately provided.

System designers and end users are cautioned to review specific warnings found in instruction sheets packed and shipped with these products.